



## *Thank you!*

Thank you for ordering a Downloadable WOOD PLAN. We hope you enjoy being a part of this new online experience and that you have fun building your wood-working project.

Please remember that this copyrighted material is for your use only. It is unlawful to share this file with someone else or to reprint it in any form.

Bill Krier  
Editor  
WOOD® magazine

### **Adobe Acrobat Troubleshooting Guide**

*If you can read this page, your Acrobat program is working correctly!  
But you may still have problems or specific issues such as printing and saving your Downloadable WOOD PLAN.*

#### **My printer won't print the text correctly**

Almost all printing problems are due to not enough free system resources memory. The files are very memory intensive since they include graphics, text, and photos. Close all other programs/applications and print directly out of the Acrobat Reader program, not your Web-browser.

#### **Patterns are not printing full size**

Make sure your printer is set to print at 100% and that "print to fit" is not checked. These settings are selected in the printer setup or printer options.

#### **I can't save my file now that it's downloaded**

You must save the plan when you download the file. Download the file again, except this time try right-clicking on the red download button. A menu window will open. Select "Save target as" or "Save link as" to save the file to your hard drive. Once saved, you can open it with Adobe Acrobat Reader.

For more details on using Adobe Acrobat Reader please visit our online help section at:  
<http://woodstore.woodmall.com/clicherforde.html>

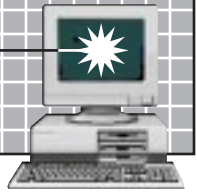

## Sitting-Pretty Folding Chair

*Who says you can't make a great concept even better? Craftsmen have been incorporating the folding-leg concept into their designs since ancient Egyptian times, but there haven't been many that look better than our rendition.*



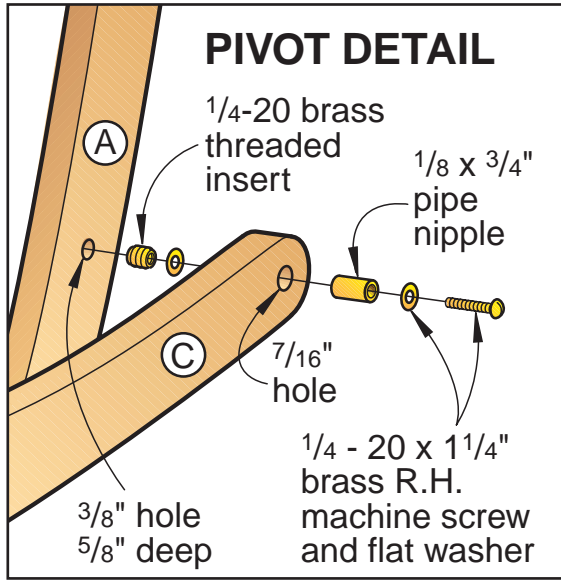

### EXPLODED VIEW

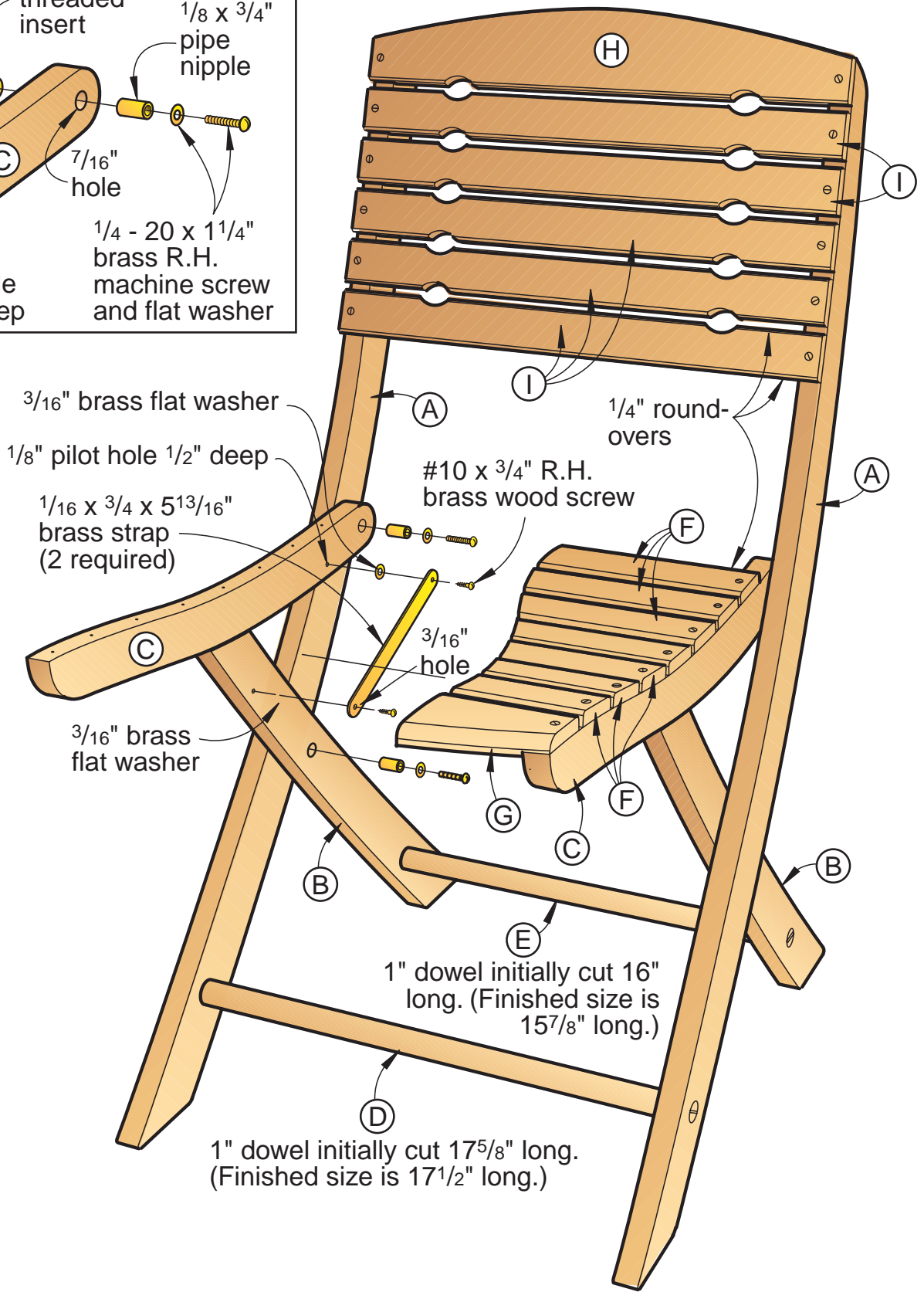

## Bill of Materials

Part	Finished Size			Mati.	Qty.
	T	W	L		
A front legs	3/4"	4 1/4"	36 5/16"	0	2
B rear legs	3/4"	2 1/16"	19 3/8"	0	2
C seat supports	3/4"	2 3/16"	15 1/4"	0	2
D* front stretcher	1" dia.		17 1/2"	0	1
E* rear stretcher	1" dia.		15 7/8"	0	1
F seat slats	1/2"	1 1/2"	15 7/8"	0	7
G front seat slat	1/2"	2 1/2"	15 7/8"	0	1
H top back slat	1/2"	2 3/4"	17 1/2"	0	1
I back slats	1/2"	1 1/2"	17 1/2"	0	5

\*Cut part to final size during construction. Please read all instructions before cutting.

**Material Key:** O—white oak.

**Supplies:** walnut for wedges; 4—1/4-20×1 1/4"-long brass roundhead machine screws; 8—1/4" flat brass washers; 4—3/16" flat brass washers; 4—1/8×3/4"-long brass pipe nipples; 4—1/4-20 brass threaded inserts; 28—#8×1 1/4" flathead brass wood screws; 4—#10×3/4" roundhead brass wood screws; 2—1/16×3/4×5 13/16" brass straps; finish.

## CUTTING DIAGRAM

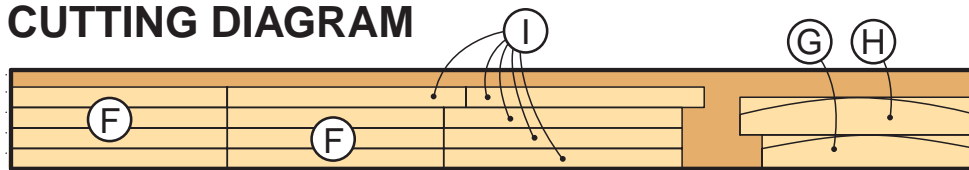

1/2 x 7 1/4 x 72" White Oak

Also needed: 1 x 36" White Oak dowel

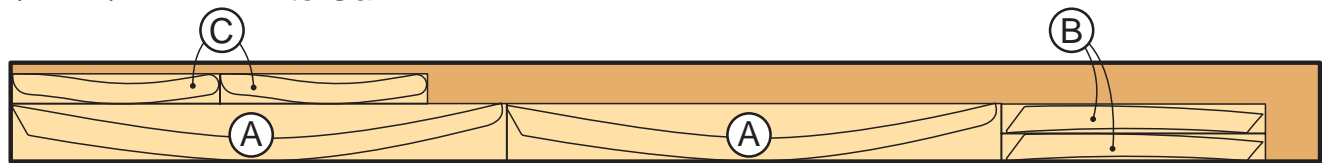

3/4 x 7 1/4 x 96" White Oak

**TIP**

**No. 1—A couple of ideas to ease installation of threaded inserts:** First, to get additional leverage on the chuck, drill a hole in the end of a 3/4×3/4" scrapwood stick to fit the chuck key handle as shown at right. Second, lubricate the threads with soft wax. A wax toilet bowl sealing ring is inexpensive and works great.

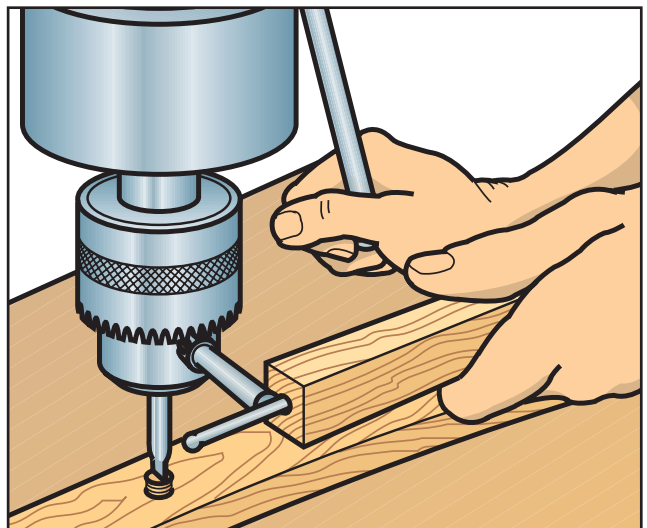

## Make patterns, then cut the parts

**1** Make and assemble photocopies of the full-sized patterns of the front leg (A), the rear leg (B), and the seat support (C). Adhere the patterns with spray adhesive to  $\frac{1}{8}$ "-thick hardboard.

**2** Cut just to the waste side of the pattern lines with a bandsaw, and then sand to the line. We used a disk sander for the outside curves, and a drum sander for the inside curves.

**3** Use the hardboard patterns to mark two of each part A, B, and C on initially oversized blanks. *Note: We used white oak for the chair because of its strength and resistance to damage from moisture. Regardless of the stock you use, select straight-grained wood for maximum strength.* Then, cut the pieces to shape, using the same cutting and sanding procedures you used to make the patterns.

**4** Use the procedure in the two-step Using the Pattern drawings below to drill  $\frac{1}{16}$ " reference holes  $\frac{1}{4}$ " deep into each blank at the centerpoint of the holes. *Note: The pairs of parts are mirror images of each other, not identical.* Then, using the information on the patterns and Exploded View for reference, use your drill press to drill holes to the marked size and depth.

**5** Install  $\frac{1}{4}$ -20 brass threaded inserts in the front legs where shown on the pattern. We used our drill press to make the installation easier. First, we chucked a  $\frac{3}{8}$ " drill bit into the drill press, and lowered it

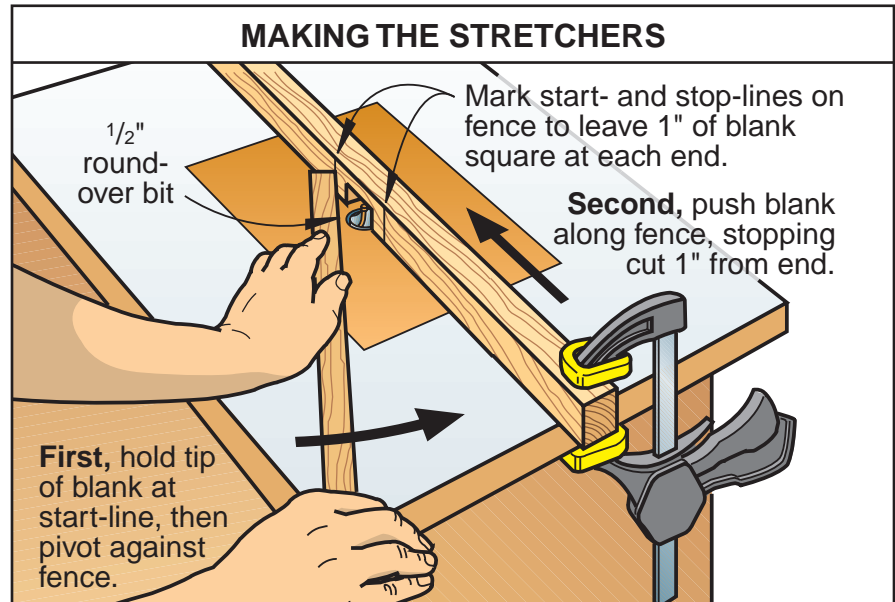

into the previously drilled hole to center the chuck. Then, we clamped the front leg to the drill-press table. Next, we replaced the drill bit with a large screwdriver bit, and rotated the chuck by hand to drive the threaded insert. See Tip No. 1 for additional suggestions to ease installation of the threaded inserts.

**6** Sand all parts to final smoothness, and then set them aside for now.

## Make the stretchers next

*Note: If you can find 1" dowels to match the lumber you chose for your chair, you can skip the dowel-making process described in steps 1 and 2 on page 5.*

**1** Prepare initially overlength blanks for the stretchers from 1x1" stock by crosscutting a 21 $\frac{1}{8}$ " piece for part D and a 19 $\frac{1}{2}$ " piece for part E. If you don't have 1"-thick stock, laminate two thickness of  $\frac{1}{2}$ " stock. *Note: You may want to make an additional blank to check later machining setups.*

**2** Chuck a  $\frac{1}{2}$ " round-over bit into your table-mounted router, and adjust the fence flush with the bit's bearing. Then, rout the square blank into a dowel by using the procedure in the Making the Stretchers drawing above right. Mark start- and stop-lines on the fence to leave a 1" length of blank square at each end.

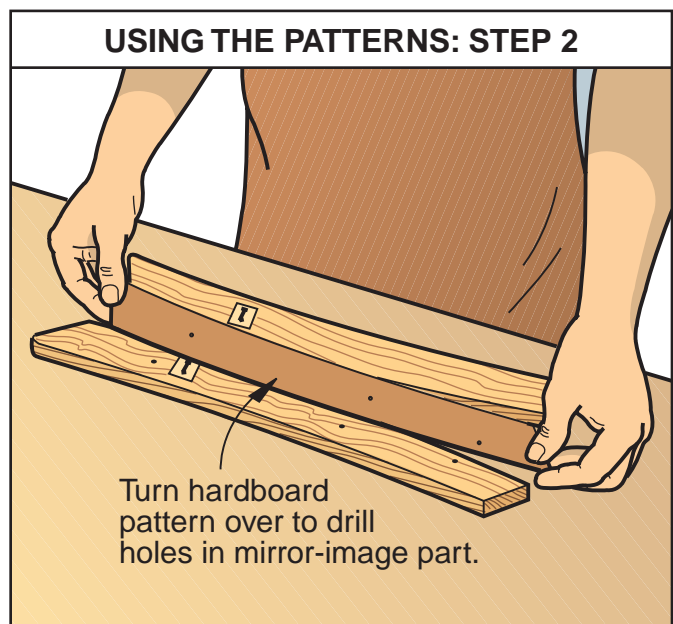
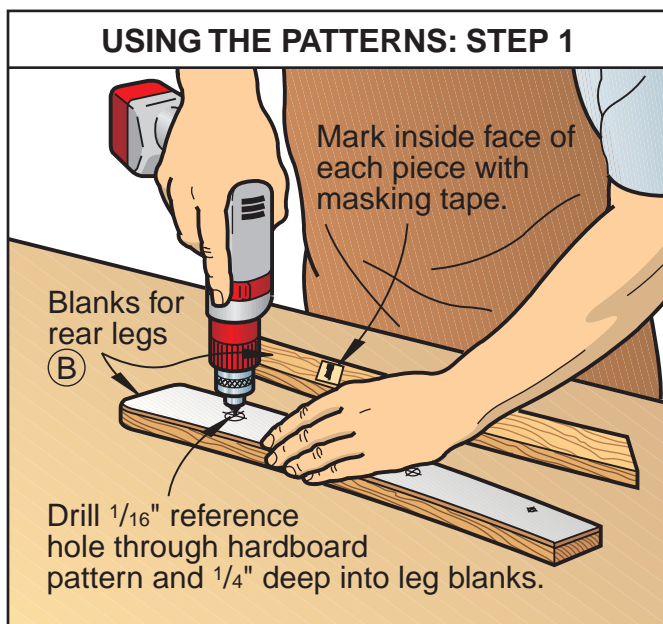



## CUTTING THE TENON

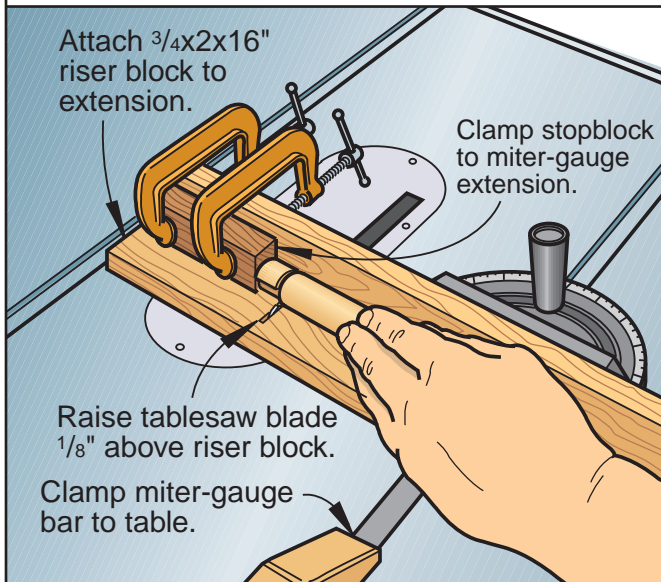

## MARKING THE WEDGE KERF

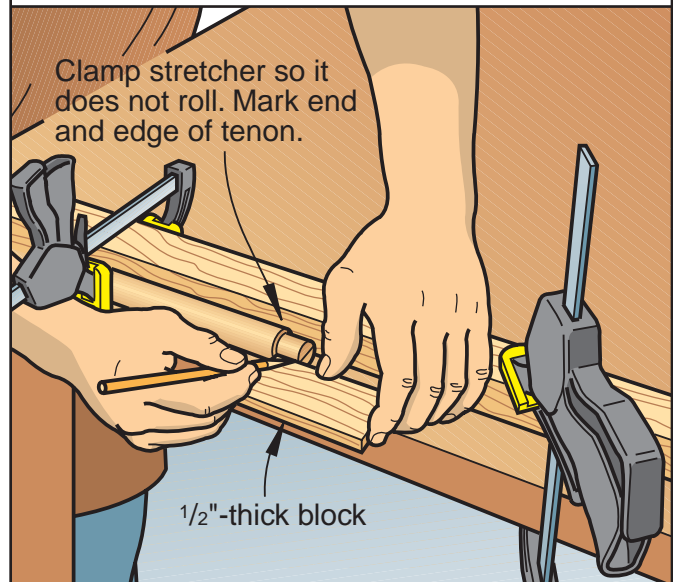

This will keep the blank from rolling as you rout.

**3** Sand the stretcher blanks smooth. Then, cut the front stretcher (D) initially overlength to  $17\frac{5}{8}$ " and the rear stretcher (E) initially overlength to 16". **Note:** This additional length allows you to cut each tenon  $\frac{13}{16}$ " long, permitting you to sand  $\frac{1}{16}$ " from each end after assembly. Refer to the Tenon and Wedge detail accompanying the Front Leg Assembly drawing.

**4** Attach an extension to your tablesaw's miter gauge, then attach a  $\frac{3}{4} \times 2 \times 16$ " riser block to the extension as shown in the Cutting the Tenon drawing. Clamp the miter-gauge bar to the tablesaw to secure the assembly. Turn on the saw, and raise the blade through the riser block until it is  $\frac{1}{8}$ " above the riser block. Clamp a stopblock to the miter-gauge extension to cut a tenon  $\frac{13}{16}$ " long. To cut a test tenon, push a length of dowel stock along the miter-gauge extension into the running blade until it contacts the stopblock. Rotate the stock clockwise to establish the shoulder of the tenon, then move the stock back and forth to remove the remainder of the tenon's waste. Check the fit of the test tenon in one of the  $\frac{3}{4}$ " holes you drilled in part A or B. Adjust the height of the blade until you get a test tenon that fits snugly, then cut the tenons on stretchers D and E.

**5** Clamp a stretcher to your workbench as shown in the Marking the Wedge Kerf

drawing top right. Then, mark the location of the kerf on the end and one edge of each tenon. **Note:** This procedure ensures that kerfs on both ends of the stretcher will be parallel. Then, cut the kerfs down to the shoulder of the tenon, using a fine backsaw. Refer to Tip No. 2 at right for a suggestion on this procedure. Sand the stretchers to final smoothness.

**6** Bandsaw walnut wedges from  $\frac{3}{4}$ "-thick stock as dimensioned in the Tenon and Wedge detail accompanying the Front Leg Assembly drawing.

### Now, assemble the legs and stretchers

**1** Dry-assemble (no glue) the front stretcher (D) between the two front legs (A), and the rear stretcher (E) between the two rear legs (B). Refer to the Rear Leg Assembly drawing. Clamp lightly to seat the shoulders of the tenons flush with the legs, then cut scrapwood spacers equal to the distance between the legs. (Ours measured 16" for the front-leg assembly and  $14\frac{3}{8}$ " for the rear-leg assembly.) **Note:** Double-check the width of the assemblies. For a proper fit, the overall width of the rear-leg assembly should be  $\frac{1}{8}$ " less than the inside width (between the inner faces of the legs) of the front-leg assembly. Then, take the assemblies apart.

**2** Using weatherproof glue (we used Franklin Titebond II), clamp the assemblies back together.

Put the curved portion of the legs upward, so four points of the assembly touch a flat surface like your saw table. Clamp the scrapwood spacers between the legs at the end opposite the stretcher to maintain parallel spacing. **Note:** It is critical that these assemblies are flat and square. Avoid excessive clamping pressure that can twist the parts. Align the kerf in the tenon parallel to the angle of the foot in the legs.

**TIP** No. 2—To make a cut that is straight across the end of the tenon and parallel to its length, start your backsaw in a diagonal position as shown below. You'll be able to sight both lines at the same time, keeping your saw right on course.

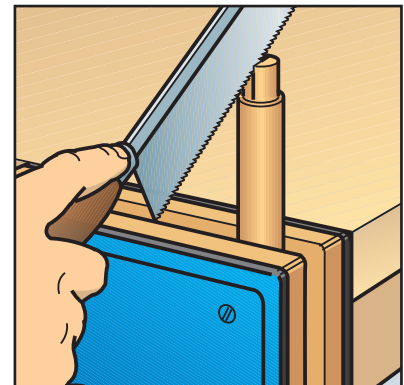

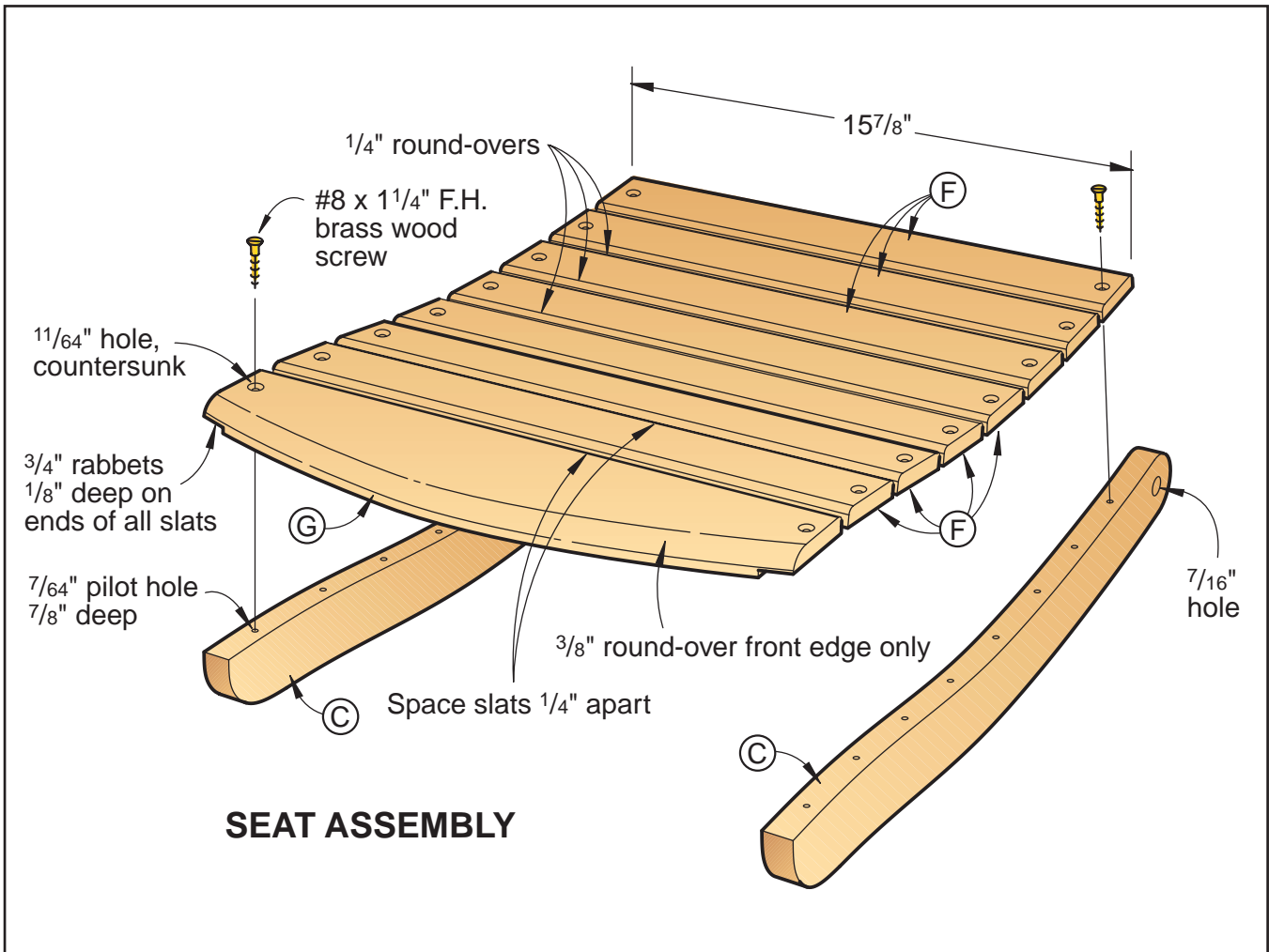
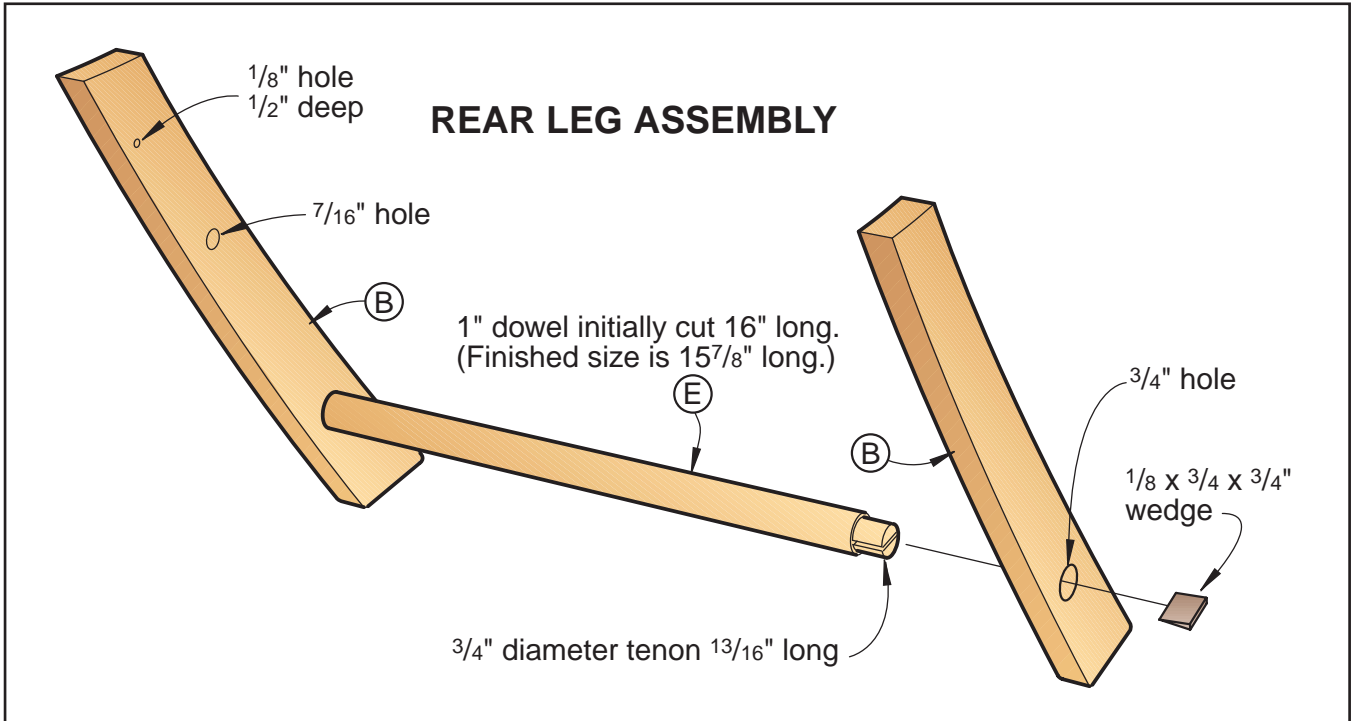



This way, the wedges will be level with the floor. Glue the wedges, then tap them into place with a hammer.

**3** Unclamp when the assemblies are dry, and then sand the ends of the tenons flush with the legs.

### Then, make slats

**1** Adjust your tablesaw's rip fence  $1\frac{1}{2}$ " from the inner edge of the blade, and rip  $\frac{1}{2}$ "-thick stock for the seat slats (F) and the back slats (I). It is a good idea to rip a few extra pieces to set up later machining operations.

**2** Rip  $\frac{1}{2}$ "-thick stock 3" wide to make initially oversized blanks for the seat slat (G) and the top back slat (H). *Note: You will shape the arcs on these parts later.*

**3** Double-check the finished length of the slats against the leg assemblies. Then, crosscut the seat slats (F, G) and the back slats (H, I) to length. We used a stopblock on an extension to our tablesaw's miter gauge to ensure that the parts were uniform lengths.

**4** Set up your tablesaw as shown in the Cutting the Slat Rabbets drawing. Then, cut rabbets into the ends of each slat.

**5** Make photocopies of the patterns of the front seat slat (G) and the top back slat (H). Then, attach them to  $\frac{1}{4}$ "-thick hardboard. Bandsaw just to the waste side of the arc, then sand to the line. A disk sander makes quick work of smoothing the curves. Mark the centerpoints of the screw locations by drilling a  $\frac{1}{16}$ " reference hole through the pattern and hardboard. Use the patterns to mark  $\frac{1}{2}$ "-thick stock for parts G and H, then cut these pieces to shape. See Tip No. 3 for a production idea. Using the holes in the patterns as guides, drill reference holes  $\frac{1}{4}$ " deep into the slats.

**6** Bandsaw just to the waste side of the cutouts where shown on the pattern of part H. Then, chuck a  $1\frac{1}{2}$ " sanding drum into your drill press, and position a 3"-wide fence below the drum, with  $\frac{1}{4}$ " of the sanding drum extending beyond the fence. Mark an oversized cutout in the fence to provide clearance for the sanding drum, and bandsaw it to shape. Then, clamp the fence to the drill-press table as shown in the Sanding the Cutouts drawing. Clamp a stopblock to the fence, and slowly pivot the slat into the sanding drum to smooth the cutout.

## CUTTING THE SLAT RABBETS

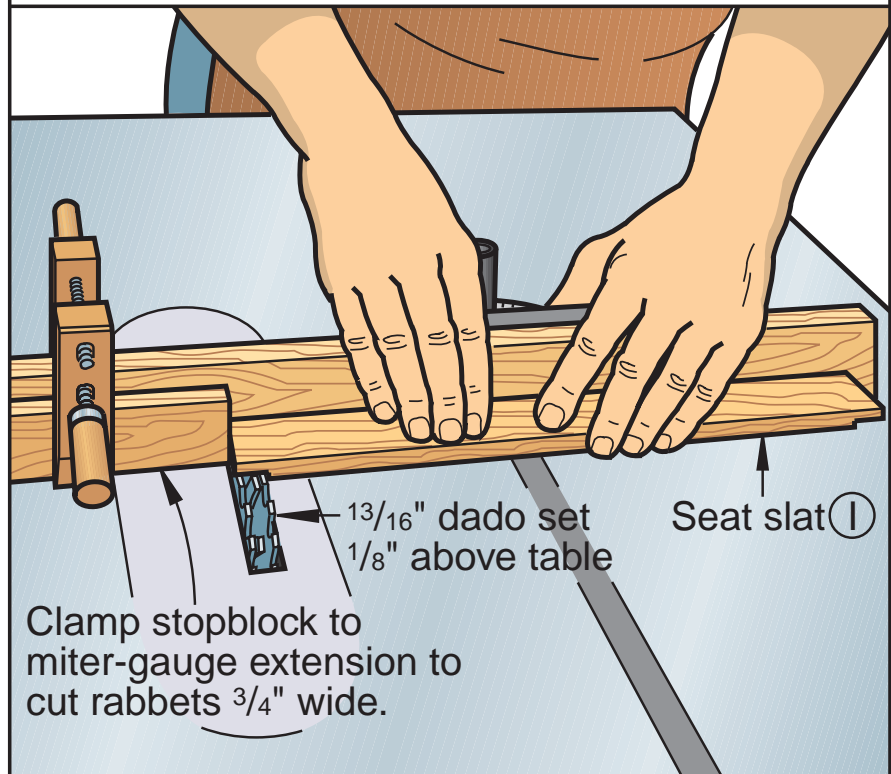

## SANDING THE CUTOUTS

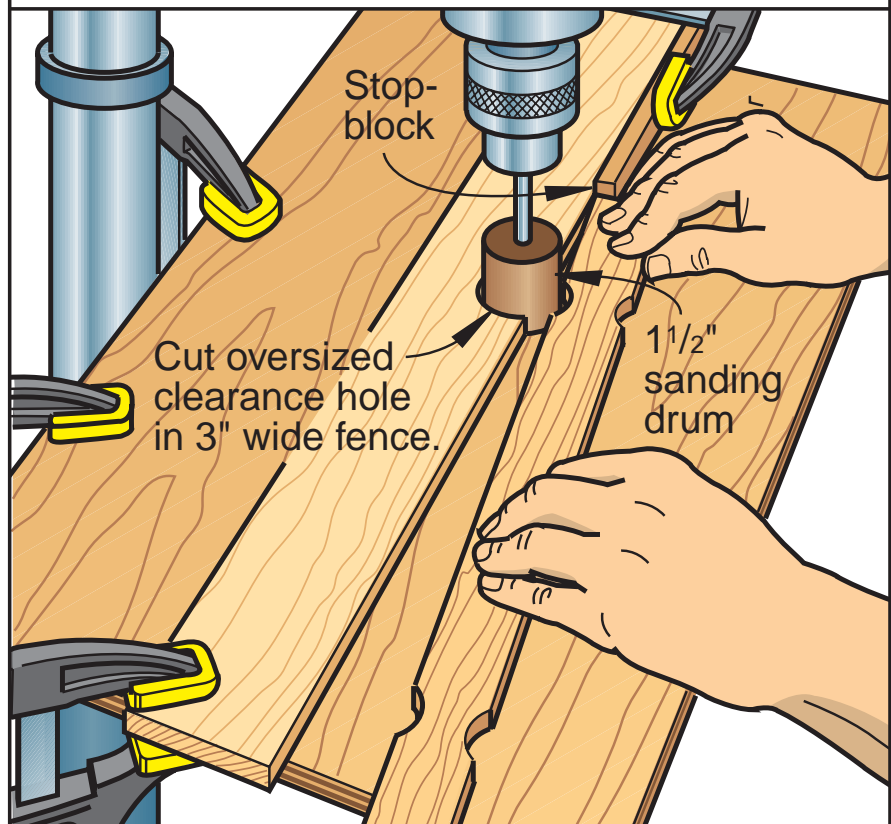

Then use either part G or H to mark the cutout locations on the back slats. *Note: The bottom back slat is notched on one edge only. All other back slats are notched on both edges.* Then, cut and sand the notches.

**7** Chuck a 1/4" round-over bit into your table-mounted router, and adjust the fence flush with the bit's bearing. Roundover the straight edges, but not the ends, of parts F, G, H, and I.

**8** Chuck a 3/8" round-over bit into your table-mounted router, and adjust the fence flush with the bit's bearing. Adhere the hardboard patterns to parts G and H with double-faced tape. Then, round over the curved edge of these parts.

**9** Set up a fence and stopblock on your drill-press table to drill countersunk 1 1/64" holes in the slats where marked on the patterns of parts G and H, and 3/8" from each end of parts F and I, centered in the width of each slat where dimensioned in the Screw-Hole detail accompanying the Front Leg Assembly drawing. Sand all slats to final smoothness.

#### Next, attach the slats

**1** Put the front seat slat (G) in position between the seat supports (C) where shown on the Seat Assembly drawing. To keep the assembly square, clamp seat slats to the seat supports. It is extremely important that all chair assemblies are square and flat. Using the holes in the slats as guides, drill pilot holes 7/8" deep into the seat supports. Then drive the screws. To prevent damage to the relatively soft brass screw, we first drove a steel screw into the pilot hole, withdrew it, then drove the brass screw. Again, you can use soft wax on the screw for lubrication. Apply weatherproof glue sparingly to the rabbets to avoid excessive squeeze-out.

**2** Insert a 1/4"-thick spacer between the front seat slat and the first seat slat (F). Repeat the process you used to assemble the front slat on all of the seat slats. Continue to check the assembly for square as you work on it.

**3** Glue and screw the top back slat (H) and back slats (I) to the front-leg assembly. Sand the ends of the slats flush with the seat supports and front legs.

#### The brass parts are easy to shape

**1** Make one photocopy of the brass strap pattern for each strap you will make (two per chair). To make the brass easier to handle, we attached it with double-faced tape to scrap pieces of 1/4"-thick plywood. Cut the blank to shape, using a bandsaw with a medium to fine blade, or a scrollsaw. Use a disk sander to smooth the ends of the blanks.

**2** Indent the centerpoints of the holes with a centerpunch or a scratch awl. Chuck a 3/16" bit into your drill press, adjust your drill-press fence, and drill the holes. You can stack the blanks with double-faced tape and drill through two at a time to ensure uniform spacing. See Tip No. 4 for a suggestion on preventing tarnish.

**3** Cut 1/8" (nominal size) brass pipe nipple to 3/4" lengths using your scrollsaw, or hacksaw. We started with 2"-long nipples. File the ends square after cutting.

#### You're ready for finish and assembly

**1** Test-assemble the chair by attaching the seat assembly to the front-leg assembly with the bushings, washers, and screws. Then, attach the rear-leg assembly to the front-leg assembly. Attach the brass straps using washers and screws. Check the fit of all assemblies.

**2** Disassemble the chair, and then epoxy the brass pipe-nipple bushings into place. Do any finish-sanding required.

**3** Apply a clear finish to all of the assemblies. We used four coats of Minwax Fast-Drying Clear Satin Polyurethane, which is suitable for interior or exterior use. We sanded between coats with 320-grit paper, then wiped with a tack cloth to remove the sanding dust.

**4** Reassemble the chair, this time using a thread-locking compound on the machine screw/threaded insert connection. We used Loctite 242 Threadlocker, available at auto-parts stores. ♣

Produced by Marlen Kemmet  
Project Design: James R. Downing  
Illustrations: Kim Downing, Carson Ode  
Graphic Design: Jamie Downing  
©COPYRIGHT MEREDITH CORPORATION 1997

#### **TIP** No. 3—Stack-cut matching parts with your bandsaw

if you are making a set of chairs. Adhere the blanks with double-faced tape, and do your edge-sanding before separating the parts.

#### **TIP** No. 4 — Use commercial brass polish on the straps, then spray them with lacquer to prevent tarnish.

Handle polished brass with gloves or a cloth before you spray it. You can brighten brass screw heads and washers before assembly with the same treatment.

The purchase of these plans does not transfer any copyright or other ownership interest in the plans, the design, or the finished project to the buyer. Buyer may neither reproduce the plans for sale nor offer for sale any copies of the finished project.

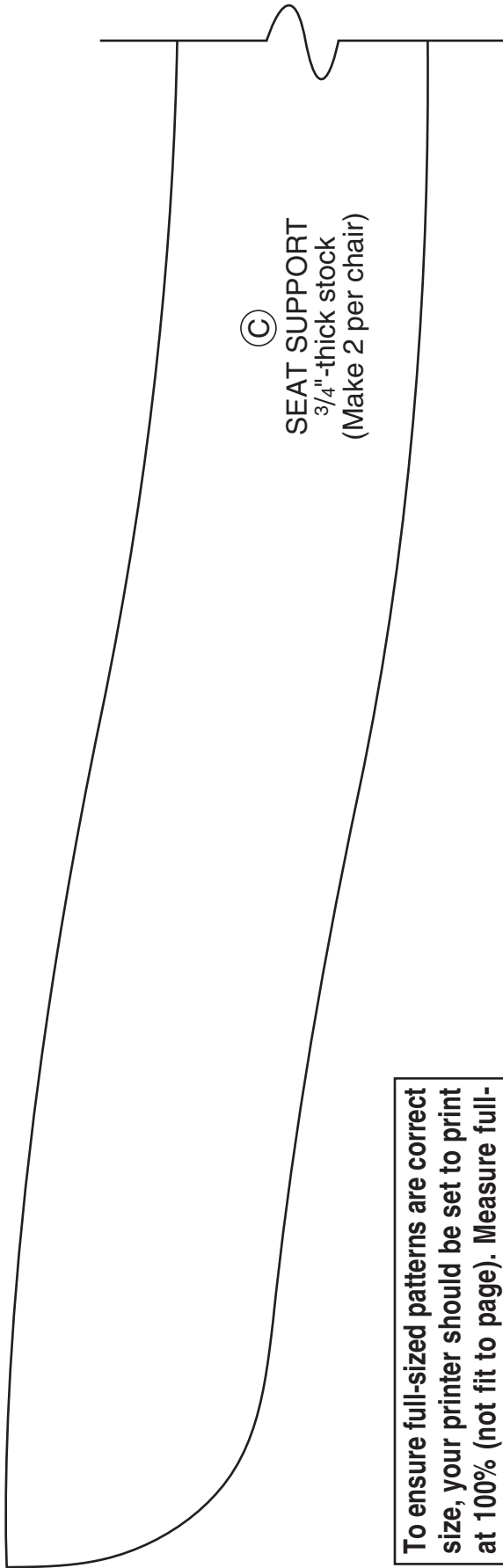

©  
SEAT SUPPORT  
3/4"-thick stock  
(Make 2 per chair)

To ensure full-sized patterns are correct size, your printer should be set to print at 100% (not fit to page). Measure full-sized patterns to verify size.

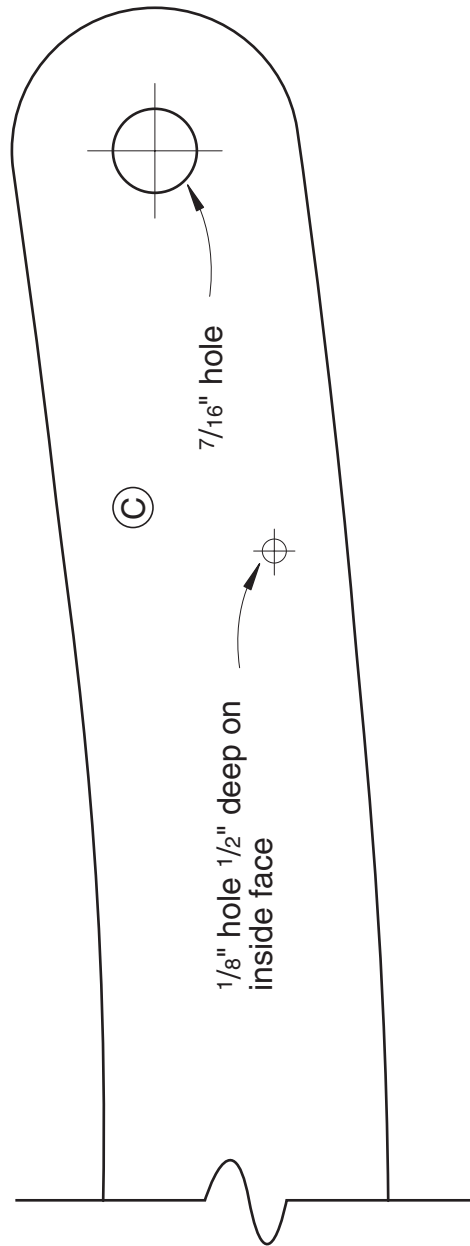
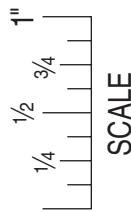

©  
1/8" hole 1/2" deep on  
inside face  
7/16" hole

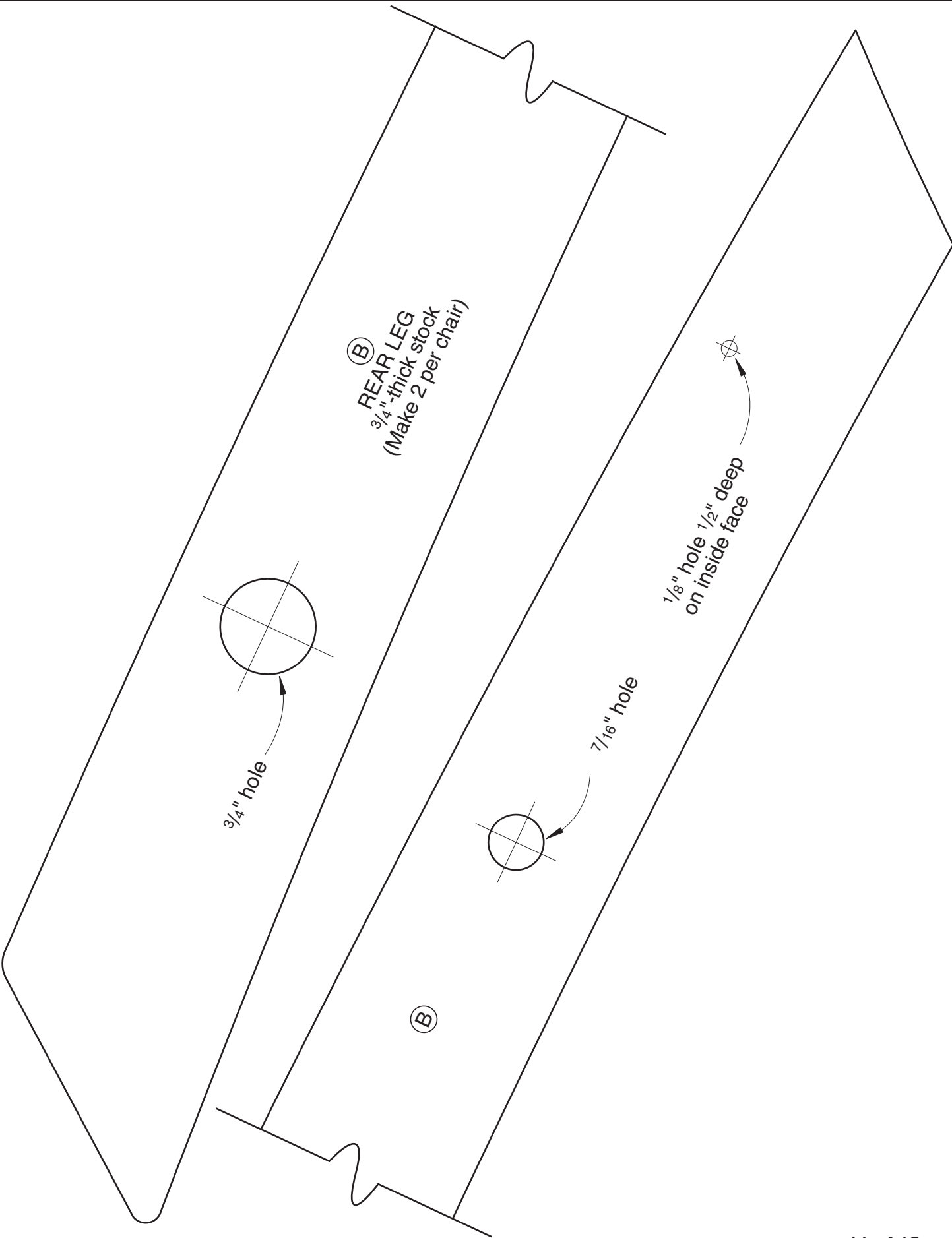

**(B)**  
REAR LEG  
 $\frac{3}{4}$ "-thick stock  
(Make 2 per chair)

$\frac{3}{4}$ " hole

$\frac{7}{16}$ " hole

$\frac{1}{8}$ " hole  $\frac{1}{2}$ " deep  
on inside face

**(B)**

A

A

(A)

FRONT LEG  
3/4" -thick stock  
(Make 2 per chair)

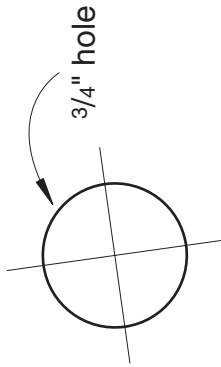

B

B

(A)

FRONT LEG

3/8" holes 5/8" deep  
on inside face

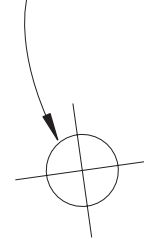

A

A

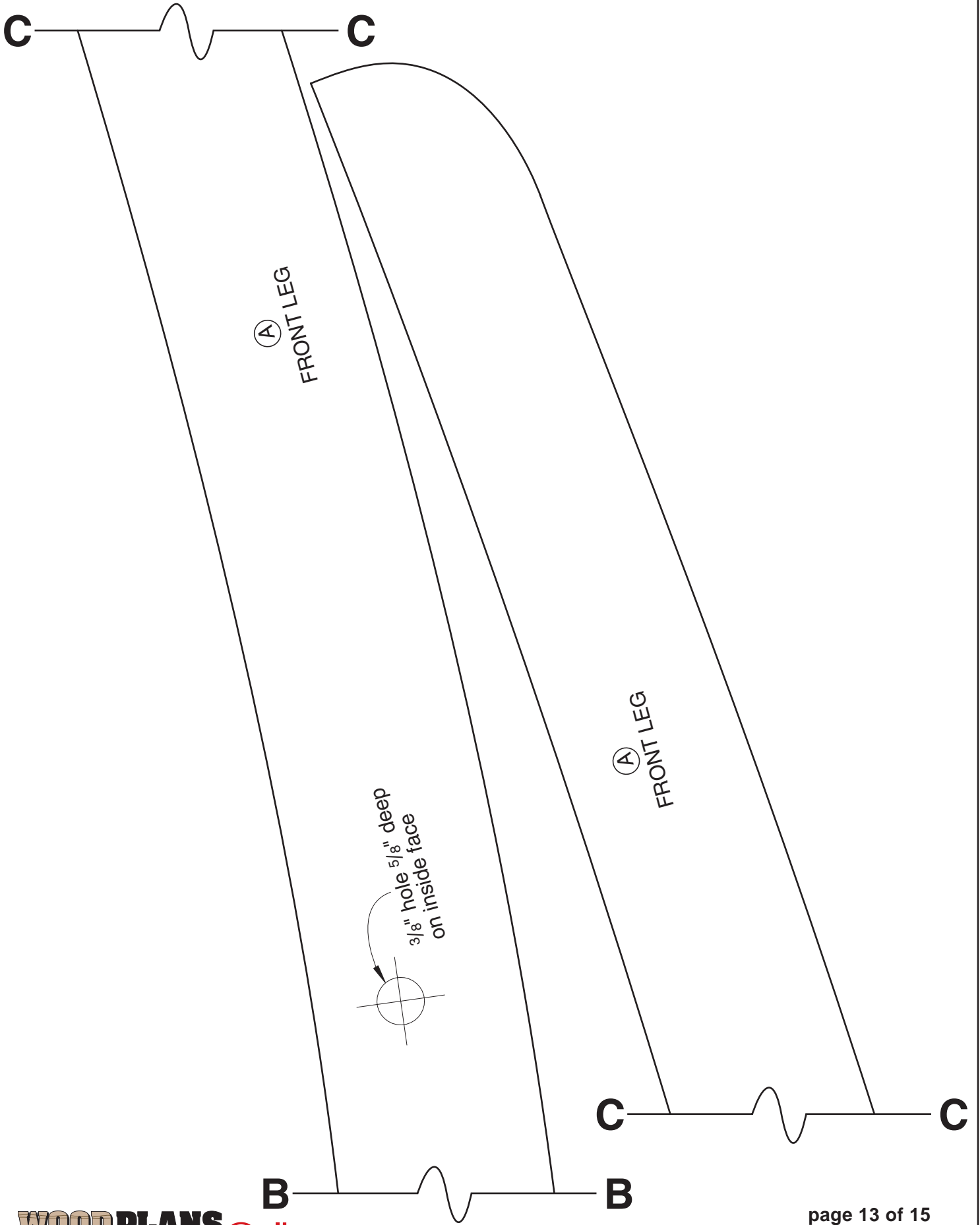

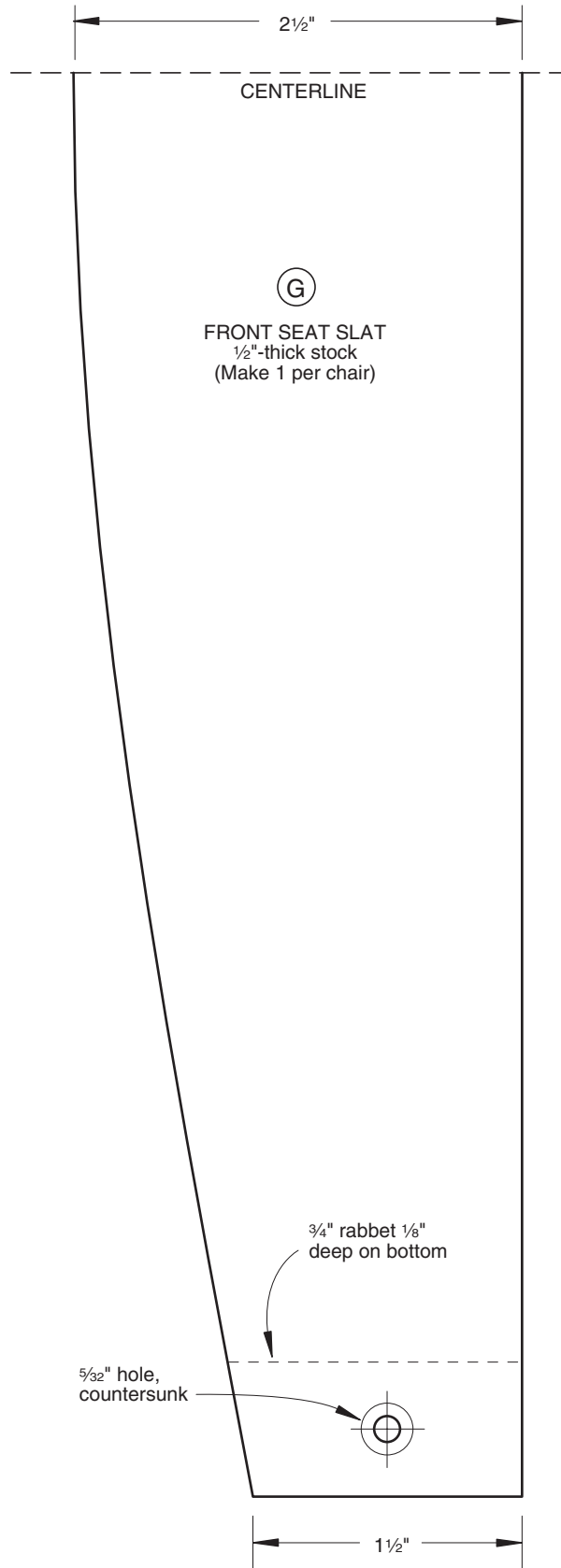
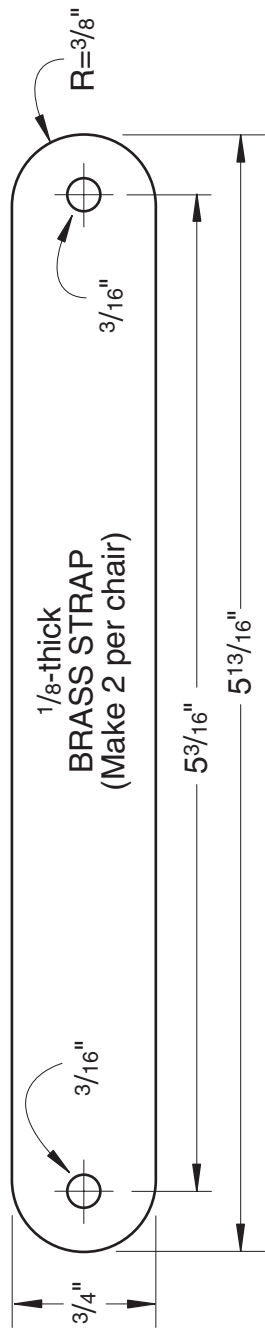

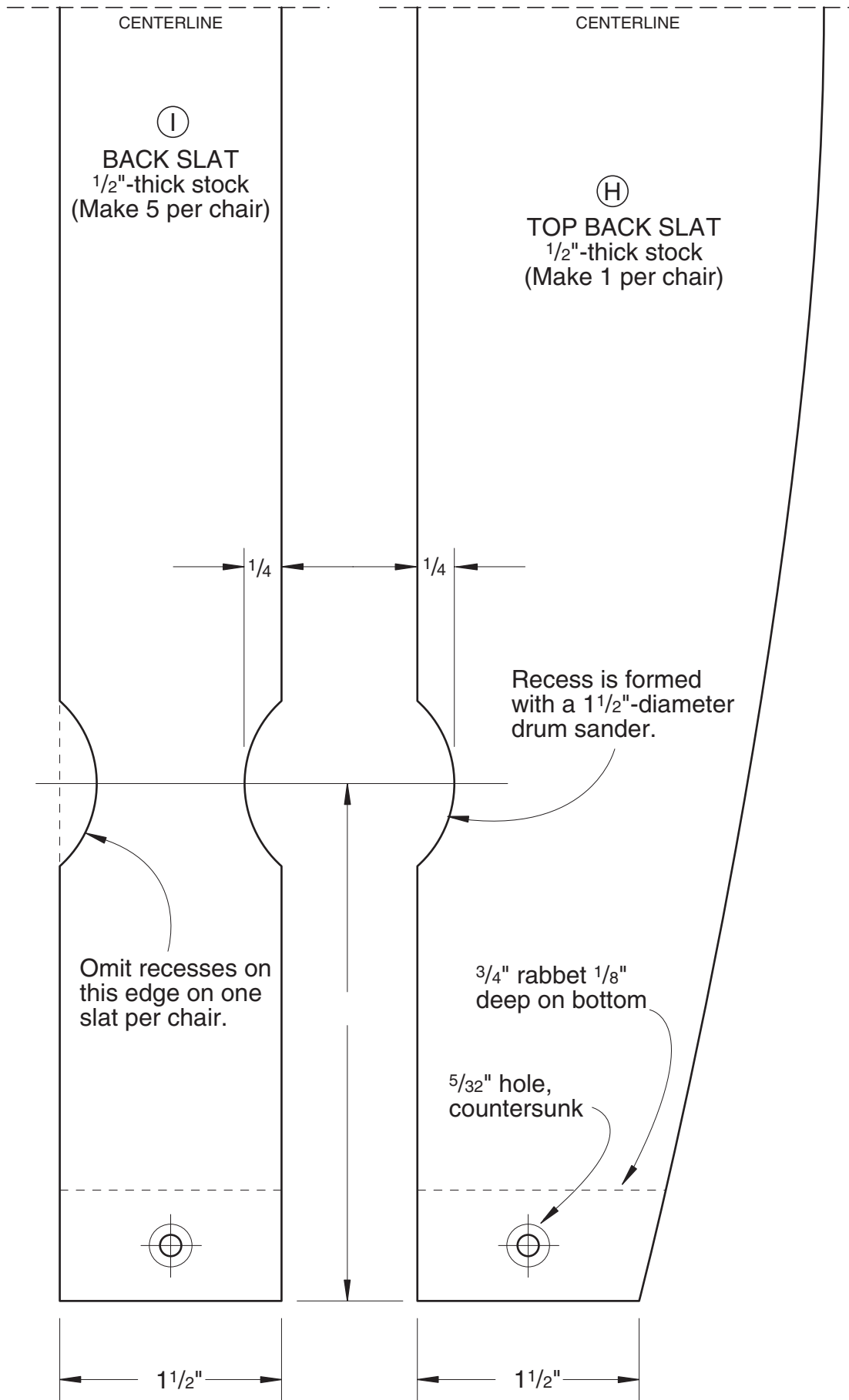



# WOODMALL® The Internet's Largest Source for Woodworking Tools and Accessories

<http://www.woodmall.com>

## Thanks for your order!

Now that you've got a detailed plan to build that perfect project, visit the WOOD MALL for the internet's largest source for woodworking tools and accessories. The WOOD MALL offers:

- Over two dozen woodworking-related stores
- More than 50,000 tools & accessories
- 24-Hour shopping
- Special sales & closeouts
- Nearly 40 tool comparison charts
- **FREE** monthly woodworking seminar

Visit Today! <http://www.woodmall.com>



Current issue not shown

Like no other magazine, WOOD helps you make the most of your shop time ... takes your skills to the next level. Every issue of WOOD is jam-packed with ...

- Smart tips, tricks, secrets and shortcuts that save you time, effort and money
- Valuable tool reviews with at-a-glance information charts that give you helpful product comparisons
- Giant full-size pattern pull-outs
- Crystal-clear step-by-step instructions, exploded diagrams, finishing secrets and techniques for that professional look – everything you need to bring out your woodworking genius!

- 2 years (14 issues) just \$44 **SAVE \$39.30 off single-copy rate!**
- 1 year (7 issues) just \$26 **SAVE \$15.65 off single-copy rate!**
- Payment Enclosed    Bill Me

Fill out information below and mail to: WOOD® Magazine P.O. BOX 37439, Boone, IA. 50037-0439 or Subscribe Online at <http://www.woodmagazine.com/subscribe>

**My Name** (please print) \_\_\_\_\_

**Address** \_\_\_\_\_ **Apt. #** \_\_\_\_\_

**City** \_\_\_\_\_ **State** \_\_\_\_\_ **Zip** \_\_\_\_\_

**Canadian Orders:** Fill in the form above. Your rate will be 1 year (7 issues) for \$41 – SAVE \$14.65, or 2 years (14 issues) for \$67 – SAVE \$44.30. Prices include postage; 7% GST or 15% HST is added. #12348 2887 RT

**U.S. and Canadian subscribers:** You also may order by credit card. Call toll free 1-800-374-9663 weekdays from 7 a.m. to 10 p.m. Central Time; Saturdays, 8 a.m. to 3 p.m.; Sundays, 9 a.m. to 3 p.m.

**Other International Orders:** 2 years for \$89 U.S. or 1 year for \$49 U.S.; prices include postage. To order by credit card call 515/246-6952 during the same hours as listed above (toll charged). Or complete this form; mail with US funds to: WOOD® Magazine, P.O. Box 37439, Boone, IA. 50037-0439 USA.

**Your Money-Back Guarantee:** You must be satisfied with your subscription or you can get a refund for all unmailed issues.

WOOD® Magazine is published 7 times a year. Savings are based on \$5.95 U.S., \$7.95 Canadian single-copy rate. The first issue mails in 8-12 weeks. Subscription prices subject to change.